

Model: TFA 1400 – Tube Axial

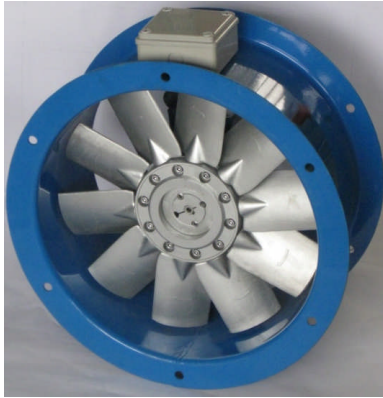

- General air movement
- Supply and Exhaust
- Smoke Spill & Fire service
- Dust Extraction

GT-Gulf (M) Sdn Bhd certifies that the model: TFA 1400 – Tube Axial shown herein is licensed to bear the AMCA Seal. The ratings shown are based on tests and procedures performed in accordance with AMCA Publication 211 and AMCA Publication 311 and comply with the requirements of the AMCA Certified Ratings Program



Casing

- Casing of mild steel hot dipped galvanised
- Motor brackets/pedestals are bolted as standard (welded available)
- Optional: epoxy powder coating

Impeller

- Pitch adjustment is infinitely variable over a wide range typically 10° to 40°
- Standard blade construction is of high pressure die cast aluminium alloy
- Fan boss are taper lock bush

Motor

- Totally Enclosed, squirrel cage induction type
- Power supply: 3 phase 415V, 50 Hz
- Suitable for operating temperature range of -35°C to +40°C
- Class F insulation and IP54 protection
- Optional: High efficient, explosion proof

Accessories (optional)

- Inlet and discharge cones/guards
- Flexible connections
- Matching flanges
- Mounting feet
- Vibration isolation mounts
- Access panels
- External terminal box
- Variable speed controls
- Sound attenuators

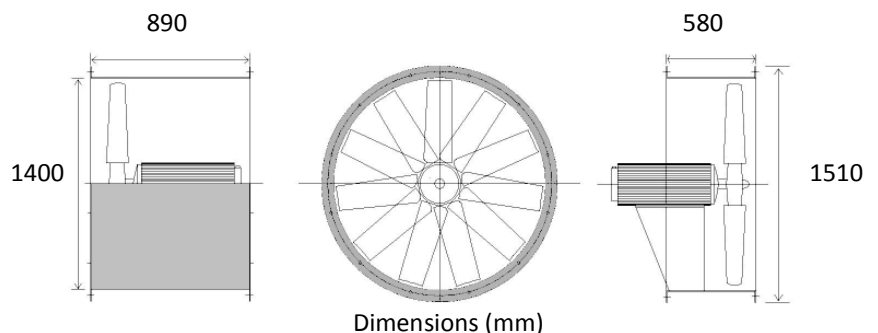

Adjustable Pitch Angle Axial Fan

SERIES TFA 1400

Impeller Code : 1400/420

Size : 1400 mm

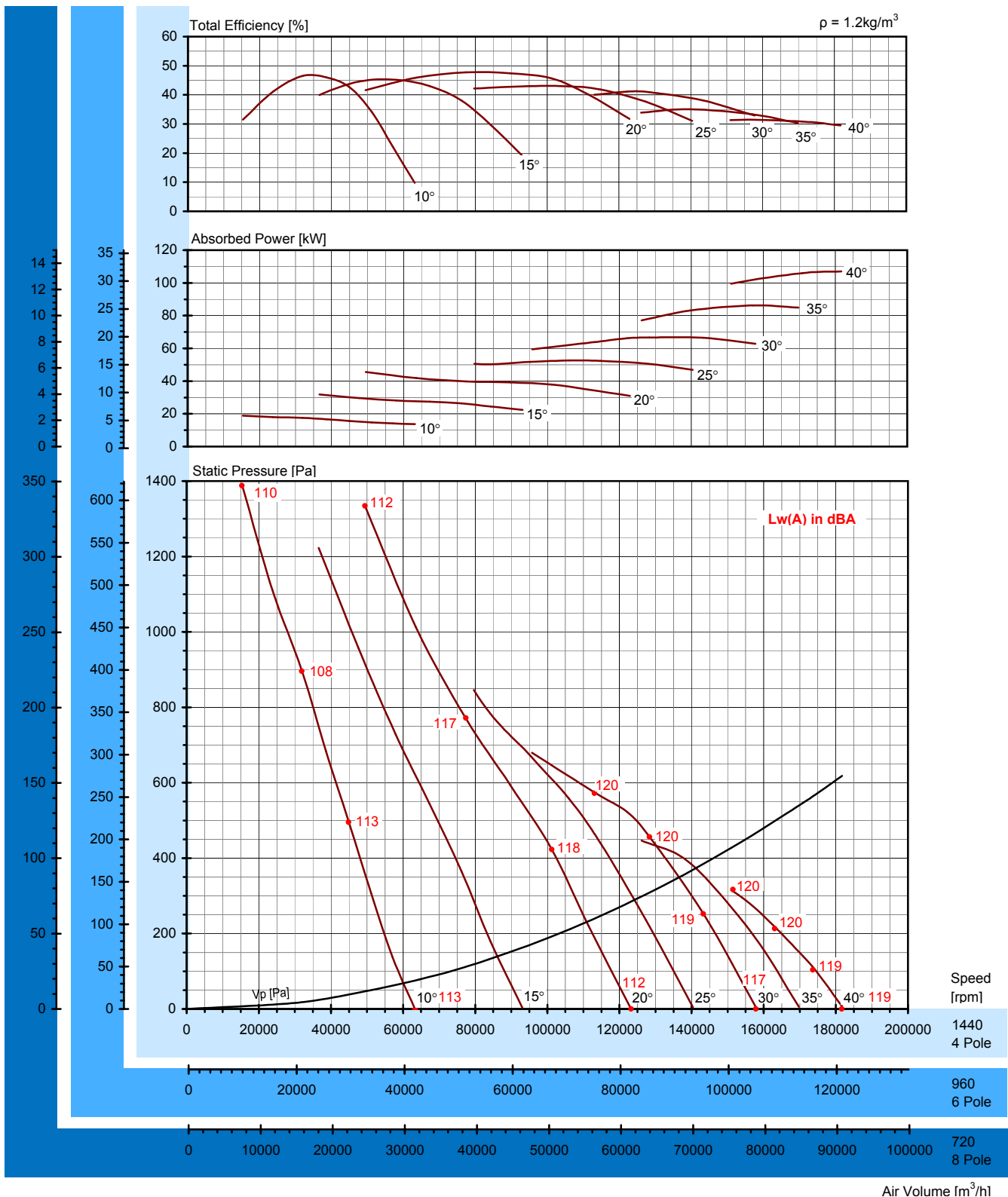

Peak Absorbed Power (kW)

N (rpm)	Blade Pitch Angle								Lw(A) in dBA	Lp(A) at 3m
	10°	15°	20°	25°	30°	35°	40°			
720 motor	2.4	4.0	5.7	6.6	8.3	10.8	13.4	-17	-37	
960 motor	5.6	9.4	13.5	15.6	19.8	25.5	31.7	-10	-30	
1440 motor	18.9	31.8	45.6	52.7	66.7	86.2	107.0	0	-20	

* Performance certified is for installation type C - Ducted inlet, Free outlet. Performance ratings do not include the effects of appurtenances (accessories).

* The A-weighted sound ratings shown have been calculated per AMCA International Standard 301. Values shown are for outlet Lw(A) sound power levels for installation type C: ducted inlet, free outlet.

* Lp(A) - dBA levels are not licensed by AMCA International



GT-GULF (M) SDN. BHD. (306488-X)
 Lot 9, Jalan 13/6, Petaling Jaya,
 Selangor, Malaysia
 Tel: 603-7957 0212 Fax: 603-7957 0398